



General Information

Load connections are made on the connector supplied with each module. The connector is fastened to the back of the mainframe. Modules can then be installed or removed from the mainframe without disturbing the wiring on the connector.

The connector has a switch to select either local or remote voltage sensing, depending on how the load is connected.

A relay connector is identified by a check mark on the **Relay** label on the connector. Relay connectors include load and sense disconnect and polarity reversal relays.

Making Load Connections

Load connections are the same on both the standard and the relay connector.

Open the Connector

Open the connector by loosening the four corner screws (M3 X 10 mm).

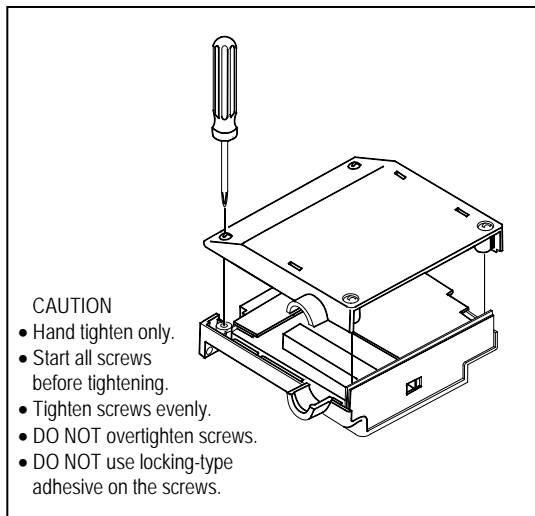

A five-terminal barrier block is provided for wire connections. The barrier block screws are 6-32 x 1/4 inch (equivalent p/n 2470-0001). The barrier block terminals are labeled as follows:

+Output used to connect the + output load wire.

-Output used to connect the - output load wire.

+Sense used to connect the + remote sense lead. Set the sense switch to **Remote** when this connection is used.

-Sense used to connect the - remote sense lead. Set the sense switch to **Remote** when this connection is used.

GND used for signal ground (GND) connections.

CAUTION



The output connector ground terminal is a low noise ground provided for convenience, such as for grounding wire shields. This terminal is not designed to function as an equipment safety ground.

Connect the Wires

Loosen the barrier block screws and connect the wires. The barrier block accepts spade or ring terminals. You can also connect a stripped wire to the barrier block. Twist the wire around under the screw terminal and tighten the screw.

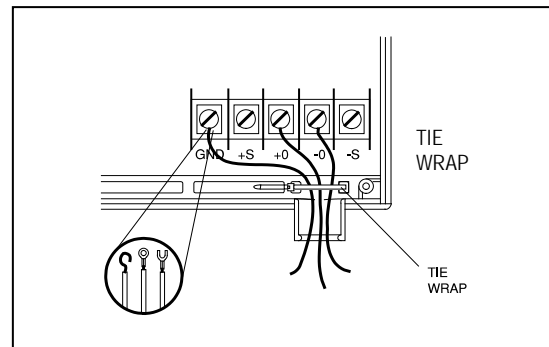

Route the wires out of the bottom of the connector as shown in the figure above. Use the tie-wrap supplied with the connector to secure the wires to the connector.

Close the Connector

Close the connector and tighten the four corner screws. Observe the **CAUTION** on the figure.

Attach the Connector to the Mainframe

Attach the connector to the back of the module on the mainframe at the appropriate slot location. Tighten the two screws (M3 x 10mm) on the connector. Observe the **CAUTION** on the figure.

CAUTION

- Hand tighten only.
- Start all screws before tightening.
- Tighten screws evenly.
- DO NOT overtighten screws.
- DO NOT use locking-type adhesive on the screws.

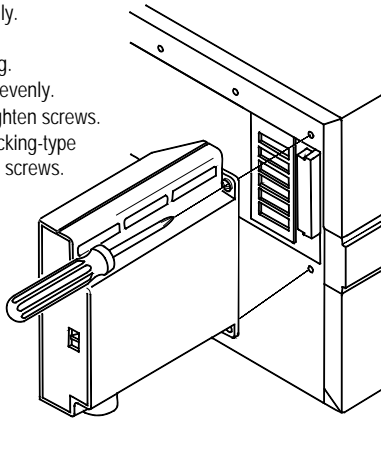

Set the Sense Switch

Each connector has a local/remote sense switch. Unless you are using remote sensing, make sure that the sense switch is set to **Local**. Remote sensing is used in applications that require voltage sensing directly at the load.

Installing a Relay Board in a Standard Connector

You can upgrade a standard connector to a relay connector by removing the standard board (p/n 5065-6998 or older style 5060-3470) from inside the connector and installing a relay board (p/n 5065-6999).

NOTE: The older style plug-in relay board (p/n 5060-3351) is no longer available and has been replaced by relay board p/n 5065-6999.

Open the Connector

Open the connector by loosening the four corner screws (refer to the figure on the first page).

Remove the Standard Board

Remove any wiring from the five-terminal barrier block. As shown in the following figure, spread the two plastic tabs located on each side of the J601 connector and lift the board out of the case.

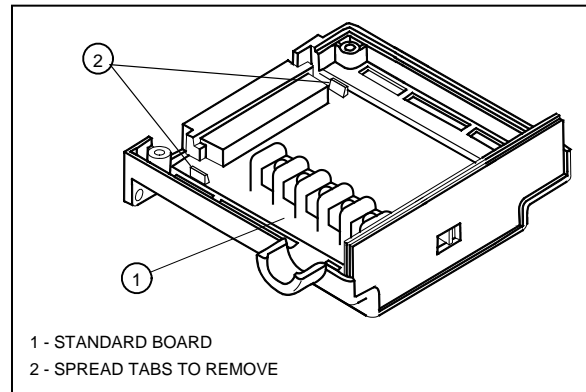

Install the Relay Board

Orient the relay board so that the switch is in the opening and snap the board into place. Reconnect the wiring on the barrier block.

Close the Connector

Close the connector and tighten the four corner screws. Observe the **CAUTION** on the figure on the first page.

With a marker, check the **Relay** box on the connector label to indicate that a relay board is installed.

This information is subject to change without notice.

© Keysight Technologies 2006, 2014

Printed in Malaysia, December 2014



5959-3366

www.keysight.com